

DVD RENTAL MACHINE S100

Service Manual

Table of Contents

Machine Overview	3
List of Replaceable Parts.....	4
List of Useful Tools and Supplies for Servicing.....	4
How it works.....	5
INITIALIZATION	5
Horizontal Initialization.....	8
Vertical Initialization	10
How to Troubleshoot	13
General	13
Common Problems	14
Test Modes.....	<u>15</u>
List of Error Codes and their Meaning	<u>16</u>

Machine Overview

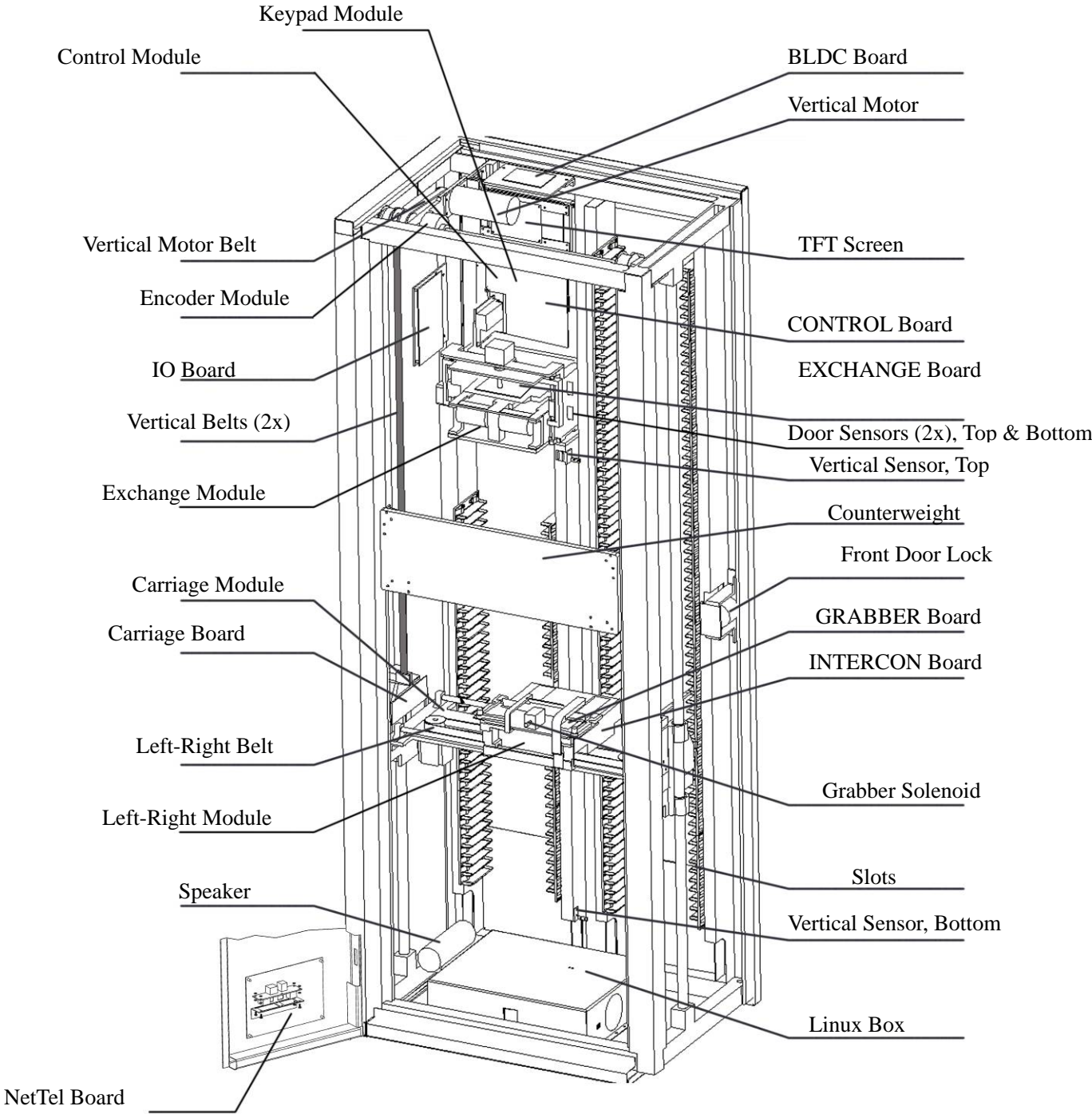

List of Replaceable Parts

	Field Replaceable Parts
1	Control Module
2	Wide ribbon cable pair
3	Main harness
4	Carriage module
5	Exchange module
6	Narrow ribbon
7	Vertical sensors plus their cables
8	TFT Screen.
9	BLDC plus harness
10	IO board
11	Speaker Module - usb power cable and audio cables.
12	Linux Box
13	Power and AV harness (external power entry cords, power cords inside the machine, power box on top of machine)

List of Useful Tools and Supplies for Servicing

	Tools	
1	Metric Allen Wrench Set	
2	Philips Head Screwdriver	
3	Flat Head Screwdriver.	
4	Wire Ties.	

How it works.

INITIALIZATION

Just like the power-up self-check of a printer, the DVD Kiosk also has a similar power-up self check. Initialization is a automatic sequence of steps that the machine performs to check everything out and make sure all movements are working. Initialization has 5 steps:

- Exchange box door opens fully and closes fully.
- The Exchange box conveyor belt turns both directions.
- Grabber Module moves forward, then backwards.
- The Left-Right Module on the carriage moves left and right. (view from back)
- The Carriage moves down, then up and performs vertical calibration.

All the motions that the machine does during a rental and return is exercised in this power-up self check Initialization process. If the machine is not able to carry out each step of the Initialization, error messages will appear on the screen.

To watch the initialization process, stand in the **back** of the machine with the back door open. The best way to be able to see all the movements is to remove the Cover of the Carriage Assembly.

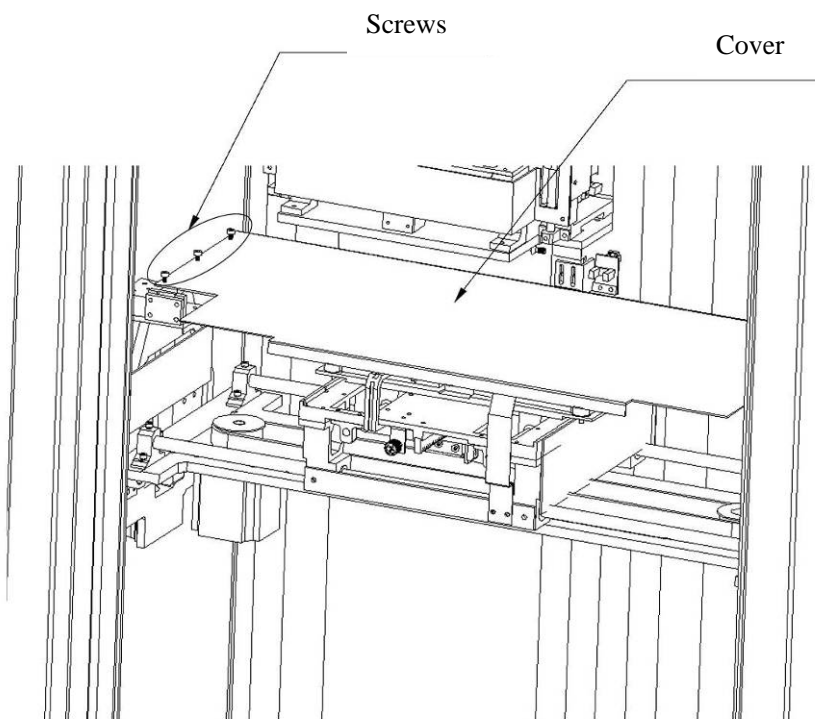

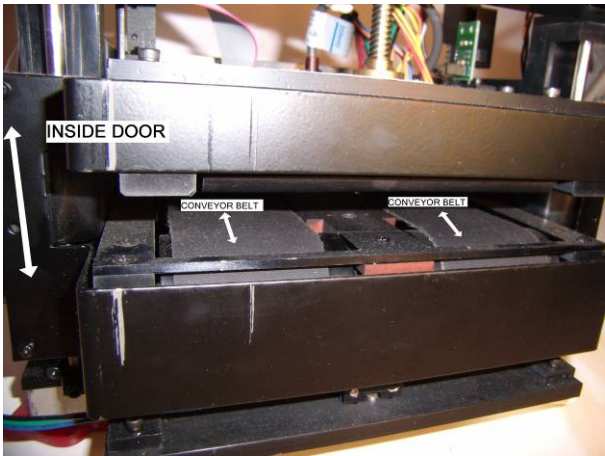
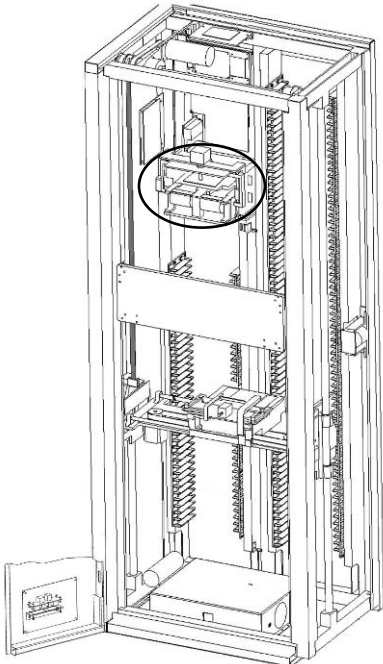

- The Inside Door will move up and down. The Conveyor Belt will roll in and out.

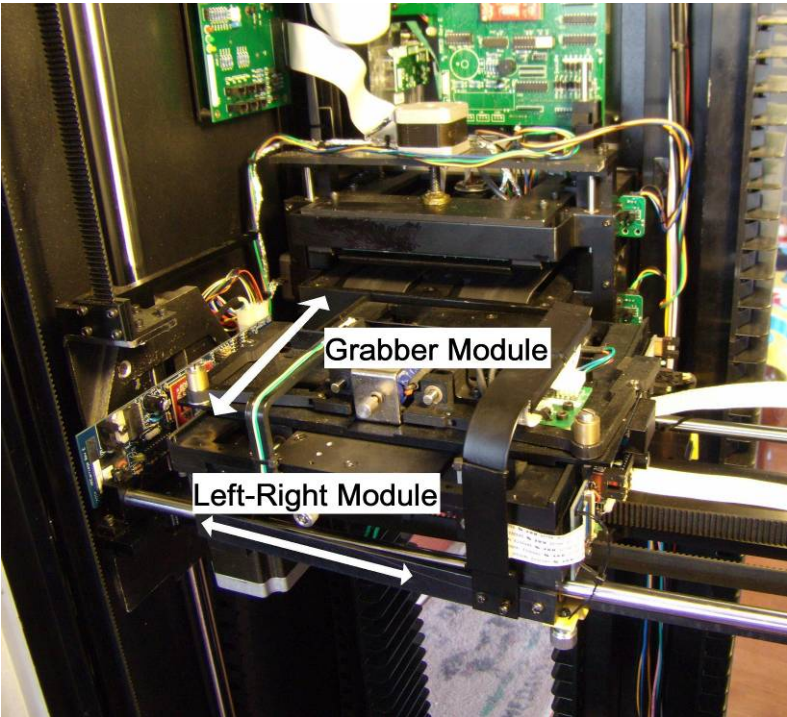
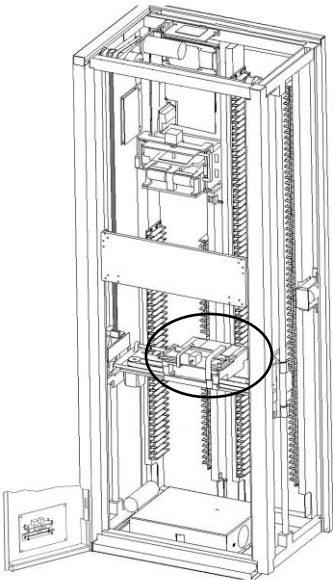

- Grabber Module moves forward, then backwards. The Left-Right Module moves left then right.

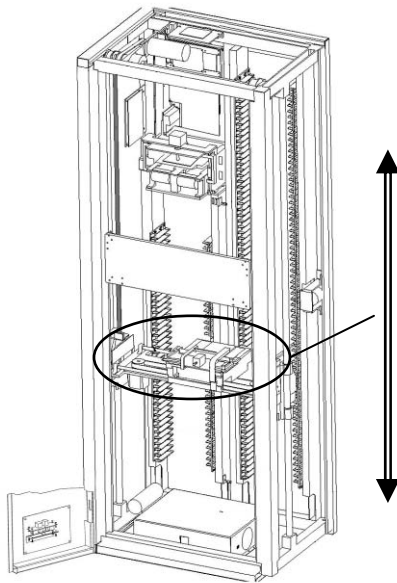

- The Carriage moves down and up several times and perform Vertical Calibration.

After Vertical Calibration, the Carriage and the Left-Right Module goes to Home Position which is right behind the Exchange Box. At this time the DVD Kiosk is ready to Rent/Return or Load/Unload DVDs and the unit is ready for use.

Horizontal Initialization

Forward Back Initialization. The Grabber Module moves forward approximately a centimeter and then moves back until the Interrupter Plate activates the Back Sensor. The Interrupter Plate activates the Back Sensor by blocking an infrared light beam inside the U-channel of the sensor. When the Back Sensor is interrupted, that is as far back as the Grabber Module can go.

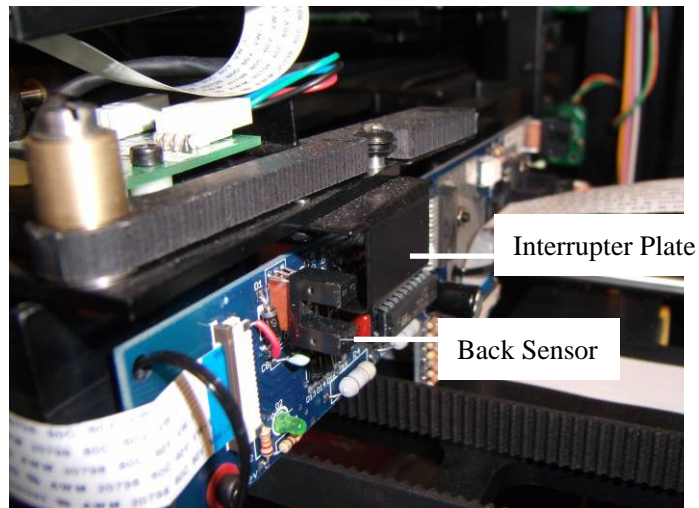
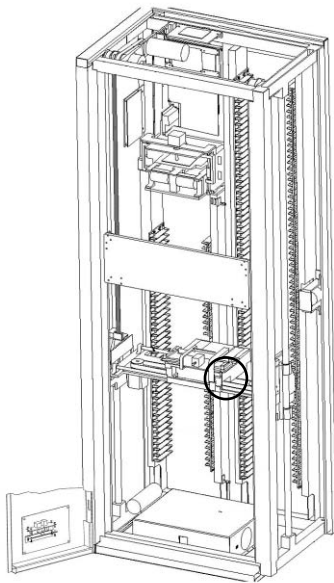

There is also a Front Sensor. When the Grabber moves forward and the Interrupter plate activates the Front Sensor, that is as far forward the Grabber Module could go. ***Simply stated, the range of travel of the Grabber Module is set by the Front and Back Sensor.***

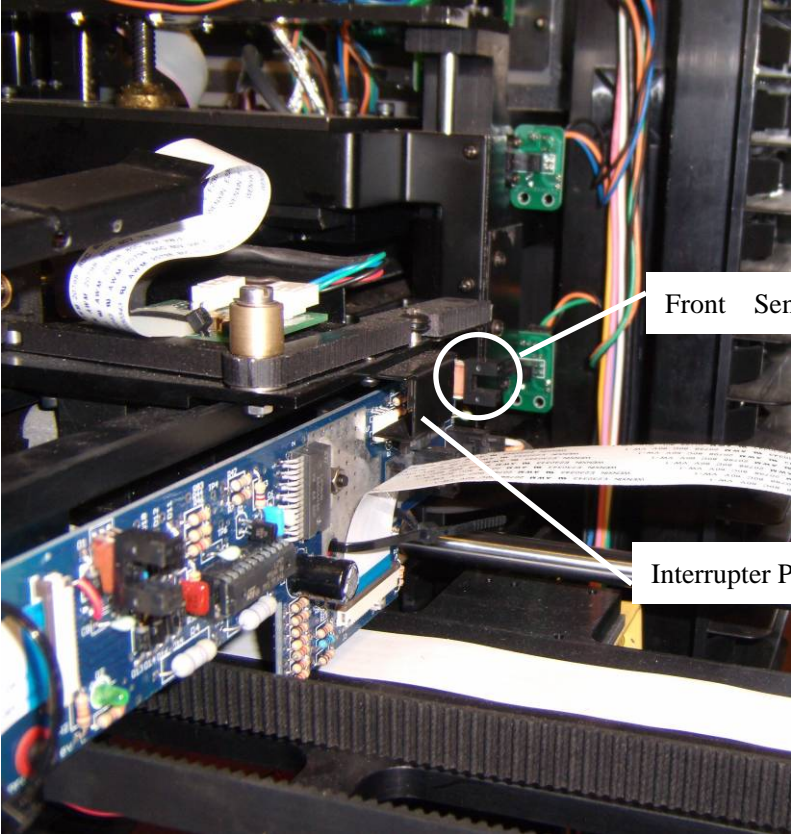

Front Sensor

Interrupter Plate

Left-Right Initialization

The Left-Right Module moves to the right (viewing from the rear), then back toward the left (the short column), until the Left-Right Interrupter Plate activates the Horizontal Home Sensor on the Carriage Board. That is the Zero Reference Position or the Horizontal Home Position. At this position

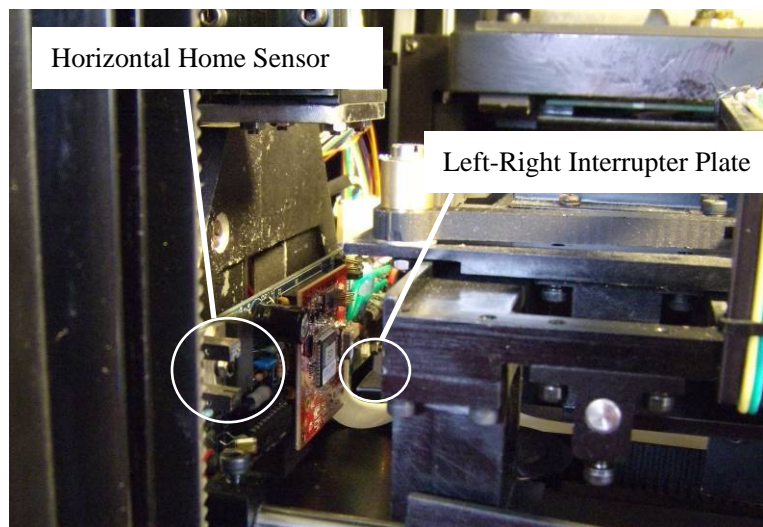
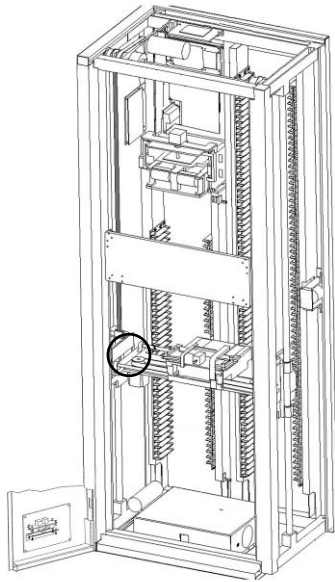

Vertical Initialization

The Carriage moves vertically to the bottom and looks for the Bottom Sensor. When the Vertical Interrupter Finger activates the Bottom Sensor, the Carriage stops and goes no further. It then does a series of acceleration tests to make sure that the vertical speed and positioning are within specifications. During the up movement, the Carriage will look for the Top Sensor. When the Vertical Interrupter Finger activates the Top Sensor, the Carriage marks that point as the Vertical Zero Reference.

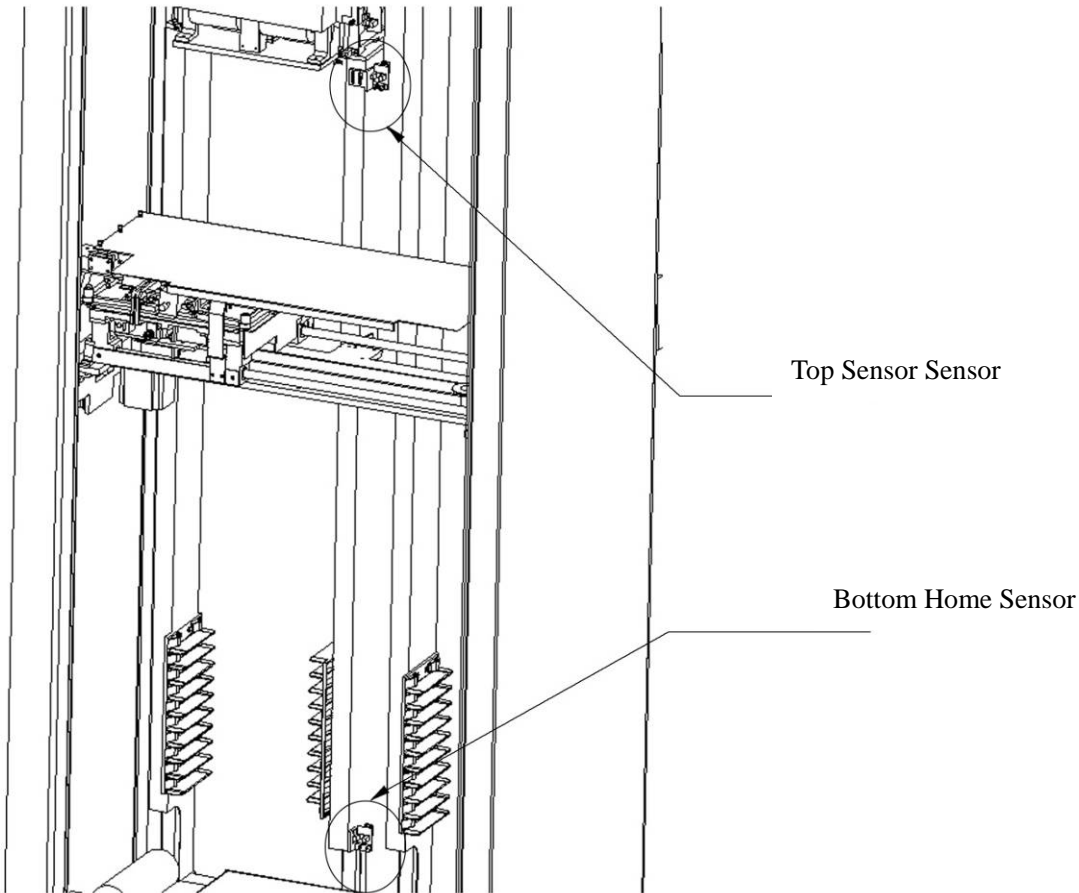

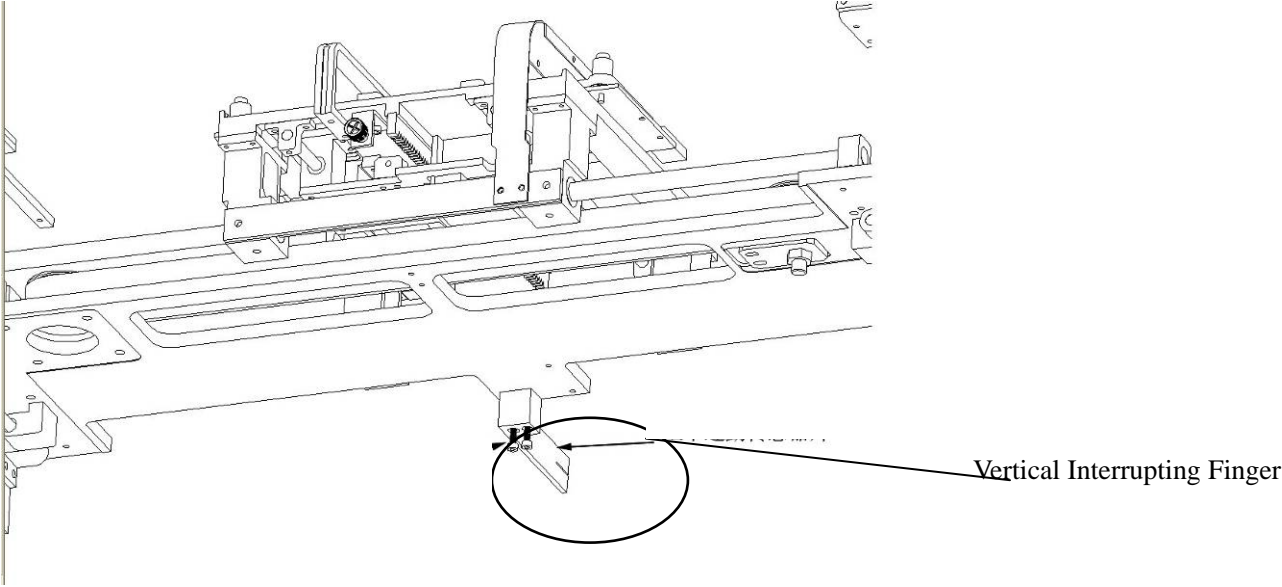

How to Troubleshoot

General

1. Make sure nothing is obstructed. When machine is Power-Off, manually move each moving part through its full travel. For example, the Carriage should be moved all the way to the top and back down all the way to down. The Left-Right Module should be moved all the way left and right. The Grabber Module should be moved forward and backwards. The Grabbing Pincers should be pushed as if grabbing a DVD (they should bounce back promptly when let go). All parts should be smooth, with no obstructions whatsoever.
2. Make sure Initialization is completely working. Watch carefully, standing from the back, door open.
3. Use the DIP switches on the Control Board to verify each function separately.
4. Verify wires and connections are plugged in. Flat flex cable (white) - check for unusual kinks, nicks, discoloration.

Common Problems

Error 86. Vertical Movement Error

Symptoms	Diagnose/Problem	Actions/Correction
Physical obstruction	DVD jam	Clear DVD, Remove Obstruction
Physical obstruction	Locking screws not completely loosened.	Loosened the screws completely
Physical obstruction	Locking tabs are bent and obstructing movement.	Bent lock tabs back with pliers to remove obstruction.
Carriage does not move vertically.	<ul style="list-style-type: none"> - Power-off the machine. - Manually move the Carriage to midpoint of the machine - Put the machine in Vertical Test Mode. - If there is still no vertical movement, then it's a BLDC problem. 	Check/wiggle BLDC harness cable on either ends. If that doesn't fix it. Replace BLDC board and harness.
During Init, Carriage moves to the ceiling, doesn't come down. Sometimes a pitch noise may emit from BLDC board mounted on the ceiling.	Vertical Home Sensor problem	Replace both Vertical Sensor and Harness
During Init, Carriage moves to the bottom, doesn't come up. Sometimes a pitch noise may emit from BLDC board mounted on the ceiling.	Vertical Bottom Sensor problem	Replace both Vertical Sensor and Harness

*** In all cases, check the BLDC harness and the Vertical Sensor harnesses are seated securely on both ends of the cable.

*** In all cases, when the machine is Powered-on, are the 3 leds on the IO board turned on? If that's not the case, replace the IO board as well.

Test Modes

Dip Switch settings allow the technician to access diagnostic programs to test individual functions of the machine.

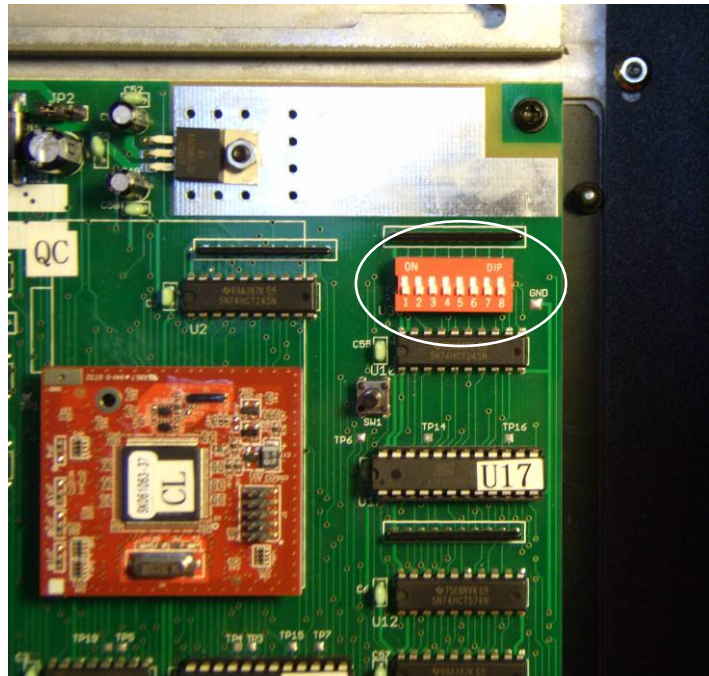
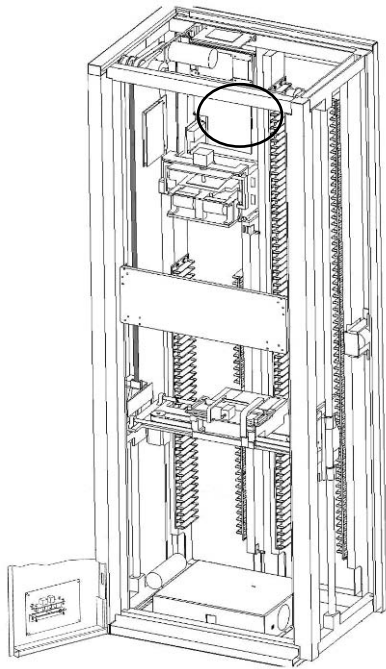

	Binary Code	Switch Settings	Meaning
1	0000 0000	All down	Normal operation
2	1000 0000	Switch 1	Continuous test: Carriage moves up/down
3	1100 0000	Switch 1 & 2	Continuous test: Conveyor rolls back/forth
4	0010 0000	Switch 3	Continuous test: DVD doors (Inside Door/Outside Doors) move up/down
5	1110 0000	Switch 1, 2, 3	Continuous test: Carriage Left-Right Module moves back and forth
6	0001 0000	Switch 4	Continuous test: Grabber Module moves back and forth grabbing a DVD

List of Error Codes and their Meaning

	Description
81, 82	A DVD is in the exchange box or something is blocking the front and back sensors in the exchange box.
83	The spring loaded exchange door can not move freely.
86	Vertical Jam. A DVD might be pushed out of the rack plate causes the vertical movement jam.
121	"exchange_to_rack no_dvd". There is no DVD in the exchange box to be fetched.
122	"exchange_to_rack retrieve_fail". Unable to fetch the DVD from the exchange slot. Possible causes: DVD case is open, serial communication error between the control board and the carriage board.
123	"exchange_to_rack Unknown Error".
124	"exchange_to_rack Error": Unable to insert into rack slot and unable to return to exchange box.
131	exchange_to_rack Error": Unable to insert into rack slot and unable to return to exchange box.
132	"Exchange_to_rack insertion fail". A DVD can't be inserted back into the rack plate after it failed to be inserted into the exchange box. Vertical alignment is off, or there is a serial communication error.
133	grabber_to_rack Unknown Error
141	Unrecognized DVD in exchange box
142	Unknown object in exchange box
143	DVD in exchange box, unable to insert into the rack
144	DVD in exchange box, unable to retrieve
145	DVD in exchange box, then got stuck on carriage